

Operating instructions for Haier myPRO^{XL} Washer



Control panel



Programs



High Temp* 60°C
Best for hygiene cycles



Med Temp 40°C



Low Temp 20°C



Non Heated



Haier myPRO^{XL}

Smart Professional Washer

**Built for smart businesses
needing extra capacity, longer
durability and ultra-speed on a
sensible budget**

Benefits and features

❖ **Top durability with 15.000+ cycle lifetime**

- Built with commercial components and last six times* longer than domestic washers
- Top quality SKF bearings in a heavy duty cast iron housing
- Durable 3 seals with 5 lips protect bearings
- More durable with 8-point spring suspension and premium steel counterweights

❖ **Faster and more efficient washing process**

- Larger load capacity: 12 kg
- Default 35 minutes for cold wash program.
- 300 G-force for greatest spin moisture reduction and faster dry time

❖ **Increased flexibility and serviceability**

- Flexible installation thanks to soft mount design and smart drain pump configuration
- OPL as default, Coin is an optional accessory
- Optional retrofitable stacking kit for washer+dryer
- Superb cleanability with 4 field adjustable wash programs
- Disinfection programs with different temperature and time selection
- Real-time clock for happy hour, promotional pricing
- 2 cycle upgrade buttons enhance revenue
- Front access for easy serviceability

*Compared to domestic machines

Main specifications at a glance

Washing capacity, kg	12
Drum volume, l	100

Consumption data*

Standard normal 60 °C, full load

Total time, min./cycle	73min
Energy consumption, kWh	1.52
Water consumption (cold+hot), l	64

Dimensios

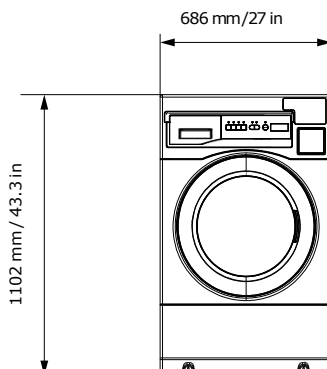

HCW12C

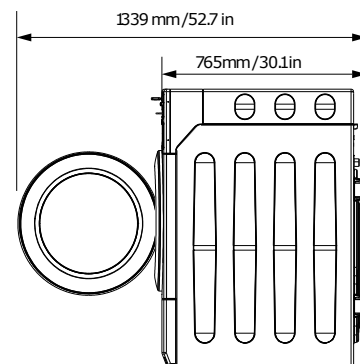

Specifications HCW12C

Wash speed, rpm	N
Spin speed, rpm (G-factor)	1050-1100
Washing noise level, dB(A)	N
Spinning noise level, dB(A)	N
Electrical connection, V/Hz/A	220-240/50/10 208-240/60/10
Drive Motor	Inverter
Heating System (KW)	2
Cabinet, top and front	Powder painted
Display	LED
Drum design	Stainless steel
Detergent compartments	3
Water inlet	Cold+Hot
Draining system	Drain pump
Drain hose (mm/in)	25 / 1
Levelling feet	4 adjustable feet

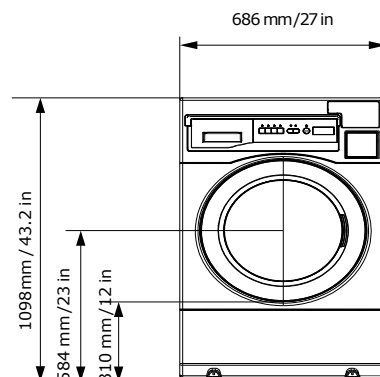

Programs

Number of programs	9
Cold / Warm / Hot / Delicate / Disinfection / Drum-Self Clean	
Number of additional functions	15
Heavy soiled / Extra Rinse	
Prewash function	Yes

Dimensions

Product - WxHxD (mm/in)	686 x 1098 x 765 / 27 x 43.2 x 30.1
Width Door Opening (mm/in)	1339/52.7
Carton - WxHxD (mm/in)	776x1174x905/ 30.5x46.5x31.7
Weight - product/carton (kg/lb)	136/146 300/322

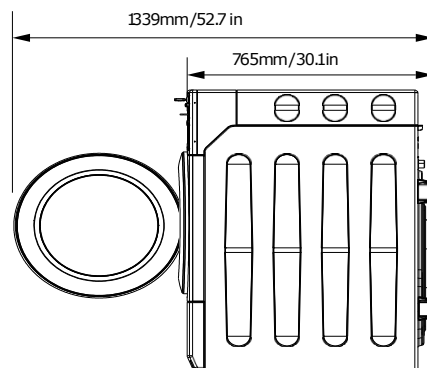

Operating instructions for Haier myPRO^{XL} Dryers



Control panel

Programs

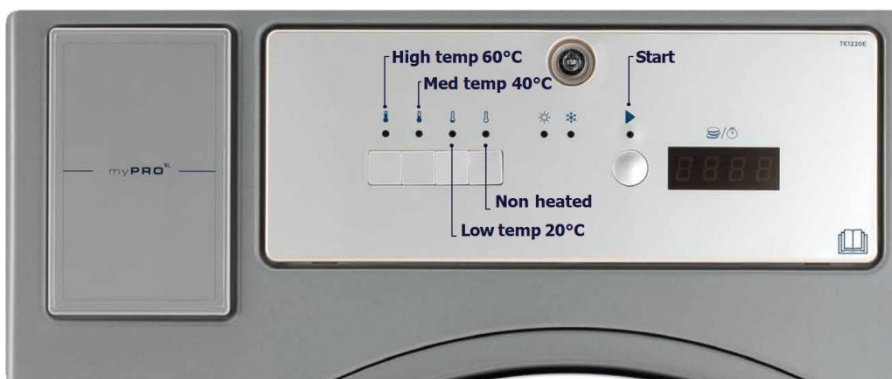

Lightly soiled



White cotton and colour-fast cotton.
 Normal soil.



Synthetic items and mixed fabric
 items. Normal soil



Delicates like acrylics, viscose, polyester
 items. Normal soil



Disinfection Cycle



Drum Self Clean Program



Heavy Soil: Add washing time by 5
 minutes.



Extra Rinse: Add one rinse



Haier myPRO^{XL} Smart Professional Dryer

Especially designed for small businesses.

The machine with a Professional heart and a Green soul on a sensible budget

boasting benefits from the professional design

Benefits and features

❖ **Top durability with 15.000+ cycle lifetime**

- Built with commercial components and last nearly six times* longer than domestic washers
- Drum supported by five roller bearings for long life
- Easy to clean, heavy duty lint screen

❖ **Faster and more efficient drying process**

- Larger drying load capacity: 12 kg
- Large capacity can handle oversized loads with ease
- Axial airflow ensures the shortest drying time and extremely low energy usage

❖ **Increased flexibility and serviceability**

- OPL as default, Coin is an optional accessory
- Optional retrofitable stacking kits for dryer+dryer
- Extra large door opening for easy loading and unloading
- Real-time clock for happy hour, promotional pricing
- Roller supported tumbler with less vibration and noise
- Front access for easy serviceability

Main specifications at a glance

Drying capacity, kg	12
Drum volume, l	218

Dimensions

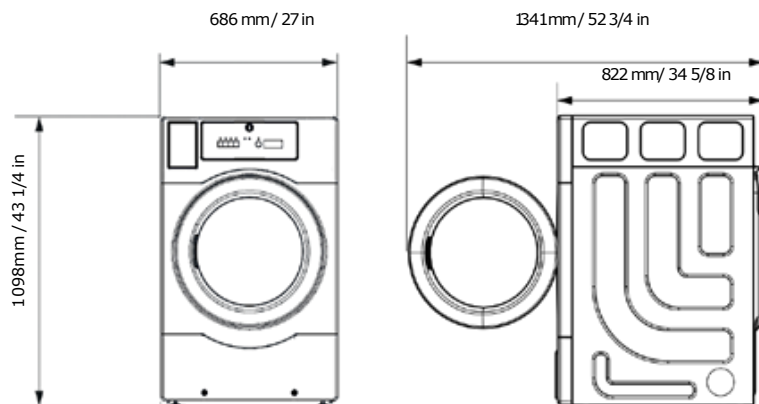

HCD12C

Haier myPRO^{XL} Smart Professional Dryer

Specifications HCD12C

Heating type	Gas
Power	4.8 KW
Electrical connection, V/Hz/A	220-240/50Hz/10
Type of drying	Vented
Air flow (CFM)	151
Motor (HP)	1/4
Declared drying noise, dB(A)	68
Display	LED
Filter	Filter with handle for easier removal
Levelling feet	4 adjustable feet

Connections

Air outlet diameter (mm/in)	100
Exhaust outlet diameter (mm/in)	100/3.937

Programs

Number of programs	4
High / Medium / Low / No heat	

Dimensions

Product - WxHxD (mm/in)	686x1098x822 27x43 1/4x32 3/8
Width Door Opening (mm/in)	1341 / 52 3/4
Carton - WxHxD (mm/in)	770 x 1290 x 880 30 3/8 x 50 3/4 x 34 5/8
Weight - product/carton (kg/lb)	70/86 154/190

