

## Apparel Processing Machines with Resin Spray Attachment 'NXP' Range & Low Spin Intact

- Front Loading, Open Pocket. For Wrinkle Free Spray Treatment, Enzyme / Stone Washing, Dyeing & Speciality Washes. 120, 240 & 360 Kg. Capacity.

### Digital Time & Temperature Control

A digital timer runs the process for the pre-set time & gives flashlights at the end of each cycle. Anchor timer controls the lowspin extract time. Auto digital temperature is comical. Individual controls for cylinder speed, water, steam & drain valve Easy to operate.

### Simple, Efficient Inverter Drive

Single motor inverter drives gas at all precision speeds required for enzyme-stain washing; dyeing turbo dyeing & other specialty washes. The low spin extract is affected by the same motor. The energy-efficient drive reduces electric peak load demands.

### Resin Mist Spray

High pressure seven nozzles manifold atomize the resin into a mist spray for uniform absorption — tremendous savings on resin costs.

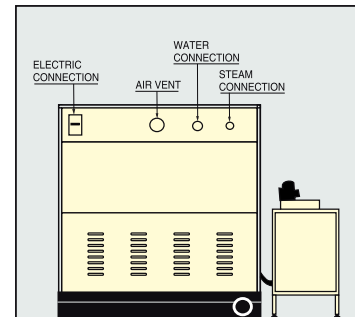
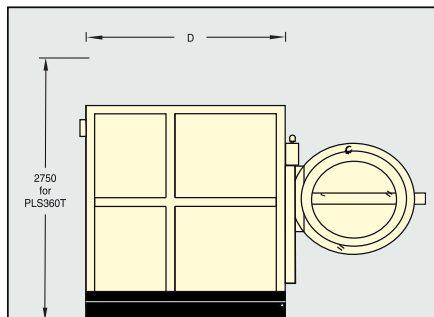
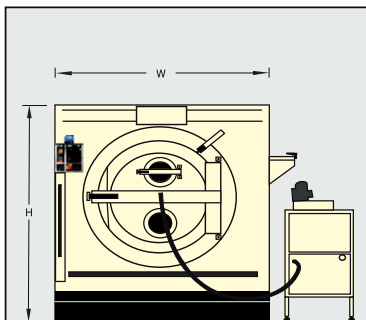

MODEL	CAPACITY dry wt. per charge (1:10)	CYLINDER SIZE VOLUME	WASH MOTOR	CYLINDER SPEEDS		LOADING DOOR OPENING	WATER CONNECTION CONSUMPTION	DRAIN	STEAM CONNECTION CONSUMPTION	AIR CONNECTION CONSUMPTION	DIMENSIONS WxDxH	NET WT / CRATED WT CRATED SIZE: WxDxH CRATED VOLUME
				WASH	EXTRACT							
NXP 120	120 Kg	Ø 1350 x 850 1216 Ltrs	5.5 KW	15 to 50 RPM (Variable)	160 RPM	Ø 800	Ø50 (2" BSP) 1200 Ltrs / cycle	Ø 100	Ø25 (1" BSP) 120 Kg / hr	Ø15 (0.5" BSP) 30 Ltrs / hr	1550 x 1900 x 2000	1880 Kg / 2110 Kg 1850 x 2200 x 2300 (1 No.) 800 x 1400 x 1500 (1 No.) 9.36 M <sup>3</sup> + 1.68 M <sup>3</sup>
NXP 240	240 Kg	Ø 1600 x 1250 2410 Ltrs	11 KW	15 to 50 RPM (Variable)	120 RPM	Ø 1000	Ø50 (2" BSP) 2400 Ltrs / cycle	Ø 150	Ø25 (1" BSP) 240 Kg / hr	Ø15 (0.5" BSP) 60 Ltrs / hr	1800 x 2400 x 2150	3150 Kg / 3580 Kg 2100 x 2700 x 2450 (1 No.) 800 x 1400 x 1500 (1 No.) 13.8M <sup>3</sup> + 1.68 M <sup>3</sup>
NXPS 15 NXPE 15	15 Kg	Ø 750 x 400 180 Ltrs	2.25 KW	15 to 50 RPM (Variable)	500 RPM	Ø 460	Ø20 (0.75" BSP) 150 Ltrs / cycle	Ø 75	PXRS 30 Ø15 (0.5" BSP) 15 Kg / hr	PXRS 30 6 / 12 KW	950 x 1000 x 1480	560 Kg / 670 Kg 1250 x 1300 x 1780 (1 No.) 750 x 1100 x 1300 (1 No.) 2.89M <sup>3</sup> + 1.07 M <sup>3</sup>

**Note:** a) All Dimensions are in MM. Standard Machines Operate on 415 ±10%, 3 Phase, 50HZ, CYS AC Electric Supply, Special Voltage on request.  
 b) Machines are also made to order as per customer's requirement & specifications.